

variset NV range wall fixed shelf with ply hangers

NV1 WH

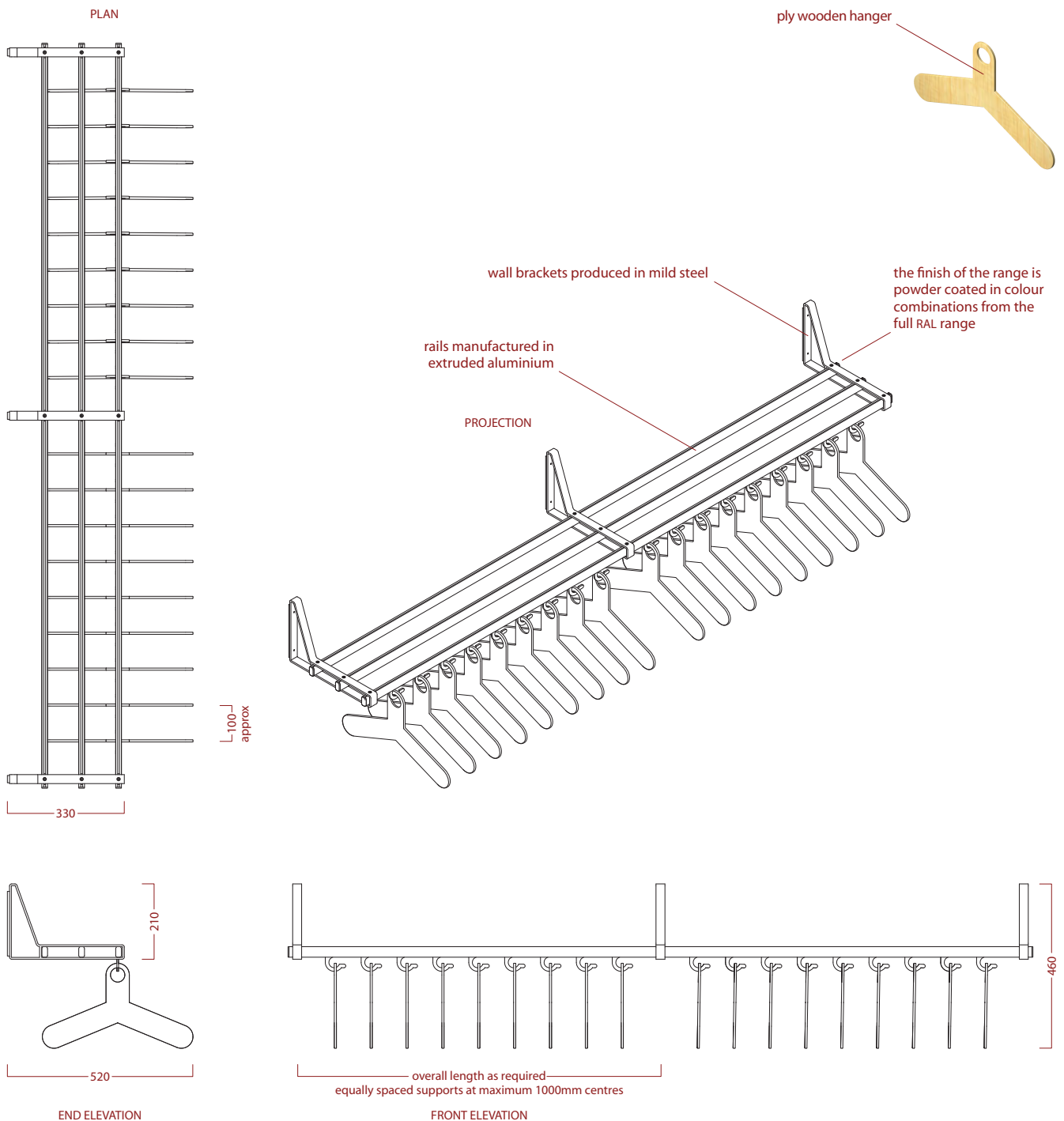

N10 GENERAL FIXTURES/FURNISHINGS/EQUIPMENT

NV1 WH 210 COAT RACKS For Changing Rooms

MANUFACTURER AJ Binns Limited, Harvest House, Cranborne Road, Potters Bar, Hertfordshire, EN6 3JF. Telephone 01707 855 555 fax 01707 857 56

email enq@ajbinns.com web www.ajbinns.com

PRODUCT REFERENCE Binns NV1WH Shelf. Wall mounted shelf and coat hanger system. (Requires at least medium density blockwork walls)

MATERIAL Brackets: Mild Steel. Rails: Aluminium. Hangers: Wood.

FINISH/COLOUR Brackets: Powder Coated. Rails: Anodized/Powder Coated (delete as necessary).

OPTIONS Numbering/CRL Cable Locks/ Claimers

binns

variset **benches, hooks, hangers & shelves** for changing rooms & cloakrooms
variset® is designed by Royal Designer for Industry Kenneth Grange CBE, RDI

AJ Binns Limited

Harvest House, Cranborne Road
Potters Bar, Hertfordshire EN6 3JF
Telephone 01707 85 5555 Fax 01707 85 7565
email enq@ajbinns.com
web www.ajbinns.com