

variset elliptical wall/floor mounted bench

EL7

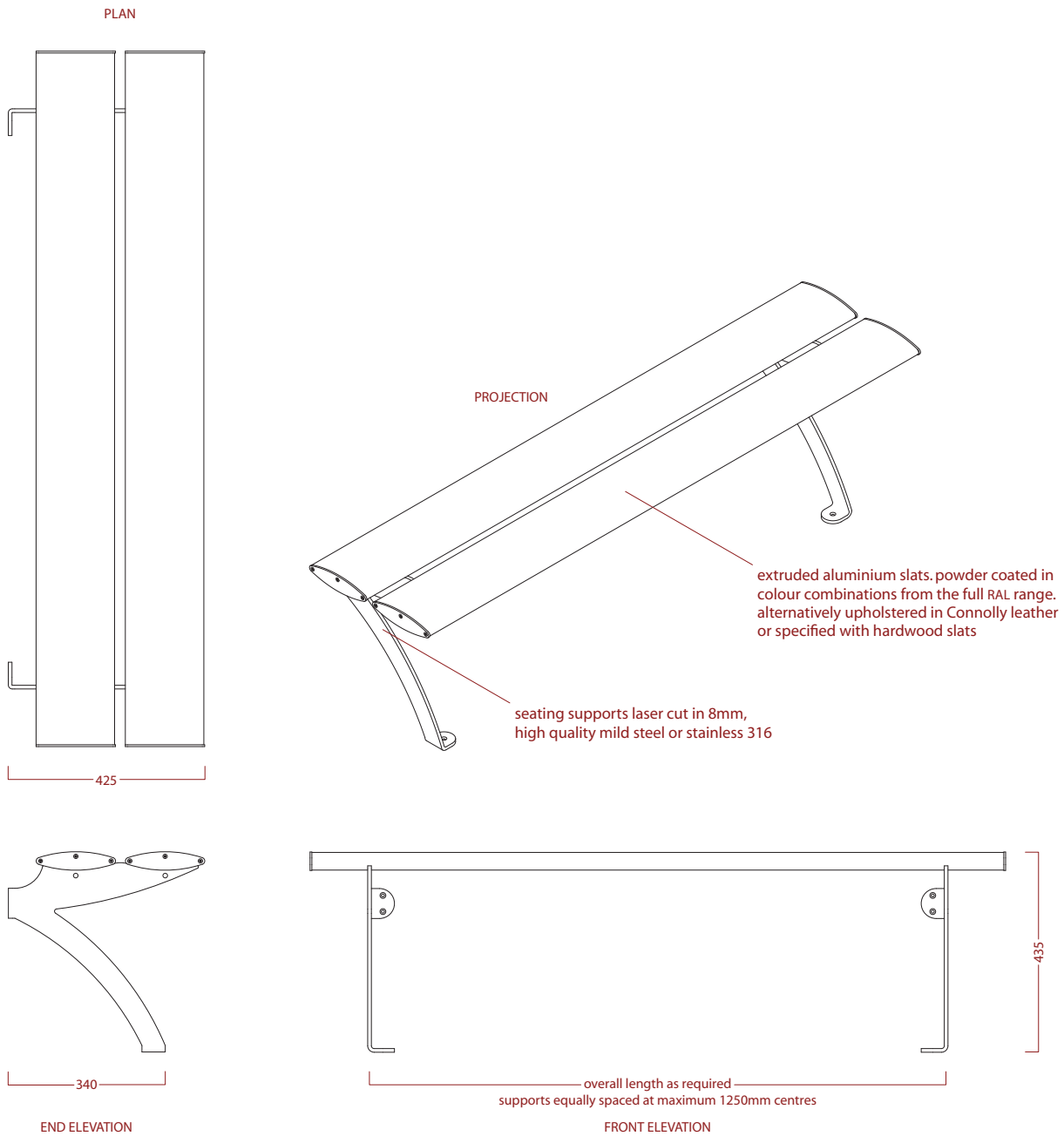

N10 GENERAL FIXTURES/FURNISHINGS/EQUIPMENT

EL7 170 BENCHES For Changing Rooms

MANUFACTURER AJ Binns Limited, Harvest House, Cranborne Road, Potters Bar, Hertfordshire, EN6 3JF. Telephone 01707 855 555 fax 01707 857 56

email enq@ajbinns.com web www.ajbinns.com

PRODUCT REFERENCE Binns EL7 Bench Unit. A wall and floor mounted bench unit.

MATERIAL Stainless steel/Mild steel/Aluminium

FINISH/COLOUR Polished/Powder Coated

FITTINGS Beech Slats/Oak Slats/Powder Coated Aluminium Slats

binns

variset **benches, hooks, hangers & shelves** for changing rooms & cloakrooms
variset® is designed by Royal Designer for Industry Kenneth Grange CBE, RDI

AJ Binns Limited

Harvest House, Cranborne Road
Potters Bar, Hertfordshire EN6 3JF
Telephone 01707 85 5555 Fax 01707 85 7565
email enq@ajbinns.com
web www.ajbinns.com